

HUKX

Sensor
Technology

Brochure
Analog Class C
albedometer

SRA01

SRA01

Analog Class C albedometer

SRA01 albedometer measures global and reflected solar radiation and solar albedo. It consists of two identical, spectrally flat Class C pyranometers with thermopile sensors—one facing upward to measure global solar radiation, the other facing downward to measure reflected solar radiation. SRA01 is fully compliant with the latest ISO and WMO standards.

Introduction

Albedo, also referred to as solar reflectance, is the ratio of reflected to global radiation. The solar albedo depends on the directional distribution of incoming radiation and on the surface properties at ground level. Albedos of typical surfaces range from about 4 % for fresh asphalt to 15 % for green grass and up to 90 % for fresh snow.

Albedo can be measured using the [SRA01](#) albedometer. Using the SRA01 is easy. The albedometer is composed of two pyranometers (model SR01): the upfacing one measures global solar radiation and the downfacing one measures reflected solar radiation. The irradiance in each direction (W/m^2) is calculated by dividing the pyranometer output, a small voltage, by its sensitivity—which is provided on the SRA01 product certificate. Albedo is calculated by dividing the two results.

Figure 1 SRA01 spectrally flat Class C albedometer.



The albedometer can be connected directly to commonly used data logging systems. More details on working principles and specifications of the pyranometers can be found in the SRA01 user manual.

Applications

Albedometers are used for general meteorological observations, building physics, roof reflectance studies, climate studies, and solar collector testing. Most applications require outdoor installation, as part of a meteorological station.

Spectrally flat

Since reflected solar radiation has a different spectrum than global solar radiation, it is essential to employ spectrally flat pyranometers for accurate measurement. SRA01 has spectrally flat sensors on board which allows global and reflected solar radiation to be measured using the same instrument with the same calibration.

SRA01 design

SRA01 consists of two identical pyranometers (model SR01): one facing up, the other facing down. The albedometer's housing is designed to fit a 3/4 inch NPS mounting tube. The cable can be led away through the tube (recommended outer diameter $< 28 \times 10^{-3} \text{ m}$; inner diameter $> 20 \times 10^{-3} \text{ m}$).

Most use cases require horizontal leveling; a bubble level is included for convenience.

Please note that the mounting tube is not included. Optional longer cables and sun screens are available when ordering.



Figure 3 SRA01 Class C albedometer, designed to fit a 3/4 inch NPS mounting tube.

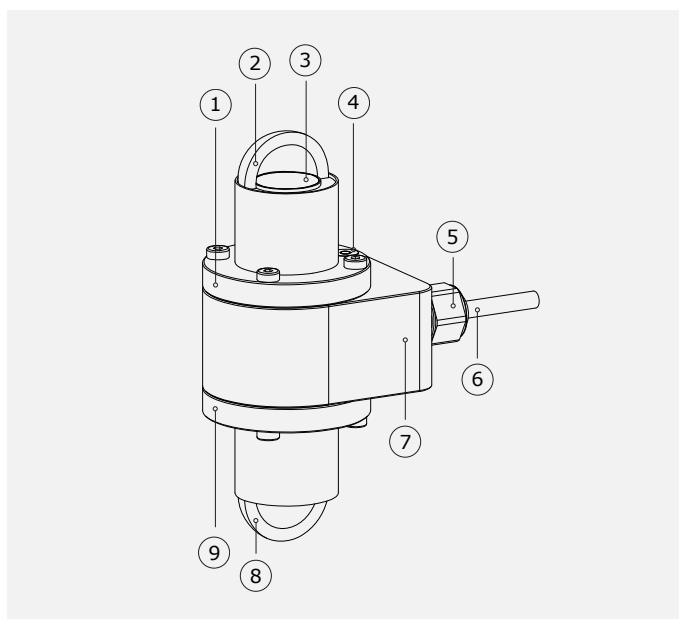

Figure 2 Overview of SRA01:

1. upfacing pyranometer body
2. glass dome
3. thermal sensor with black coating
4. bubble level
5. cable gland
6. cable
7. albedometer body
8. glass dome
9. downfacing pyranometer body.

Suggested use

- agricultural networks
- general meteorological observations
- building physics
- roof reflectance studies

Standards

The instrument meets classification standards ISO 9060 and WMO-No. 8. Calibration follows ISO 9847 and ASTM G207-11 protocols.

Options

- longer cable in multiples of 5 m, cable lengths above 20 m in multiples of 10 m
- sun screens

See also

- [SRA300-D1](#): spectrally flat Class A albedometer for higher accuracy albedo measurements
- [SRA200](#): spectrally flat Class A albedometer for high-accuracy albedo measurement
- [SRA100](#): spectrally flat Class B albedometer
- alternative instrument: [NR01](#) for solar and longwave radiation balance
- [ALF01](#) and [CMF01](#): mounting fixtures for easy leveling and crossarm mounting of albedometers
- View our complete [range of solar sensors](#).

SRA01 specifications

General specifications		calibration traceability	to WRR
measurand	global solar radiation and reflected solar radiation	measurement range	0 to 2000 W/m ²
optional measurand	albedo or solar reflectance	spectral range	285 to 3000 x 10 ⁻⁹ m
optional measurand	net solar radiation	sensitivity (nominal)	15 x 10 ⁻⁶ V/(W/m ²)
included sensors	2 x identical ISO 9060 spectrally flat Class C pyranometers	rated operating temperature range	-40 to +80 °C
mounting	3/4 inch NPS tube (not included)	temperature response	< ± 3 % (-10 to +40 °C)
calibration uncertainty	< 2.4 % (k = 2)	standard cable length	5 m (see options)

About Hukx

Hukx is the leading innovator in solar radiation and heat flux sensor technology. We are proud to set the standard in high-accuracy measurement, and to be working at the heart of the energy transition.

Customers worldwide rely on our bestselling pyranometers and heat flux sensors. From sensor design and selection to supply and recalibration, we support you across the entire lifecycle.

Hukx is headquartered in the Netherlands, with locally owned representative sales offices in the USA, Brazil, India, China, Southeast Asia, and Japan.

Let us help you select the best sensor for your application. Get in touch with our experts today via: info@hukx.com

© Hukx

Version 2502

We reserve the right to change specifications without prior notice.

www.hukx.com

HUKX